



MODEL
215 Z

TOTAL CAPACITY	11,500	in ³
BASKET CAPACITY	8,100	in ³
NESTING	10	in
WEIGHT	52	lbs
TRAILER CAPACITY	560	shop. carts

FINISH	
BASKET	NYLON CHROME
FRAME	CHROME

FEATURES

Integrated handle, rear caster, stress tube between rear wheels - much stronger.
 Double wire truss basket - stronger, lighter.
 Drops down gravity assist baby seat - less likely to bind when nesting.
 7 ga. (0.177) rear caster - stronger, cleaner.

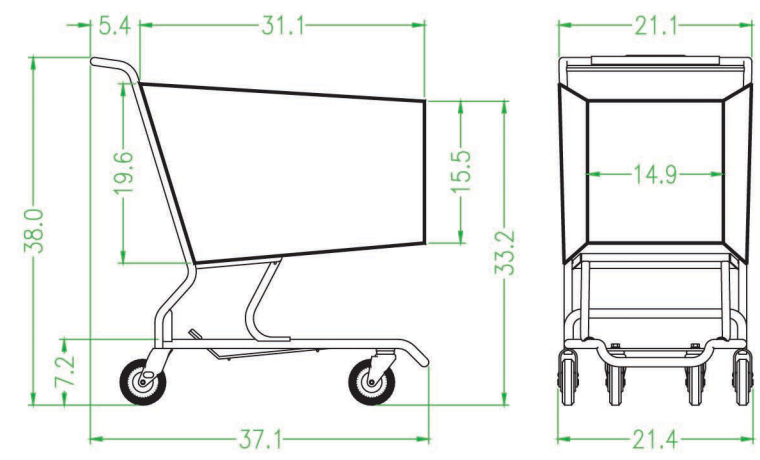

R.W. Rogers Company
 610 S. Kirk Rd., St. Charles, IL 60174
 Phone: 630-377-9033 * Fax: 630-377-2073
<http://www.rwrogerscompany.com>



MODEL NUMBER
215Z

NAME
SHOPPING CART

DATE
08/10/07