

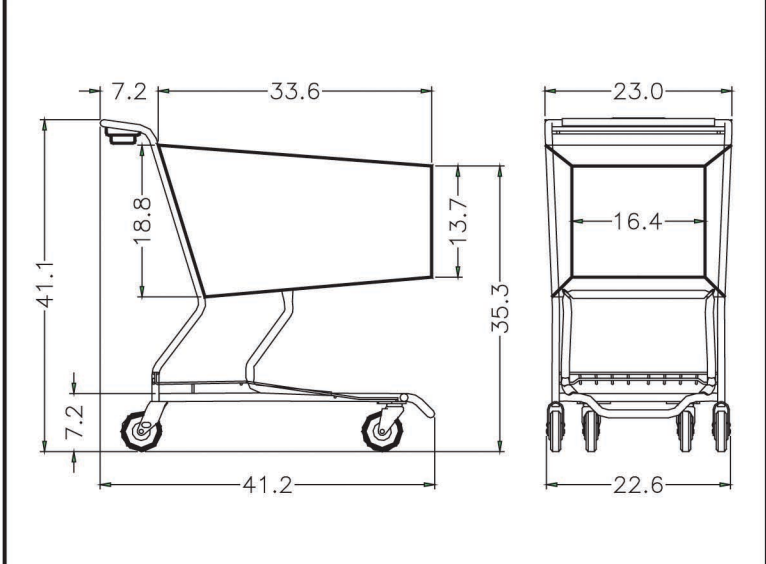

<b>MODEL</b> <b>348 W</b>	
<b>TOTAL CAP.:</b>	15,700 in <sup>3</sup>
<b>BASKET CAP.:</b>	9,000 in <sup>3</sup>
<b>NESTING:</b>	12 1/2 in <sup>3</sup>
<b>WEIGHT:</b>	64 lbs
<b>FINISH</b>	
<b>BASKET</b>	E-COAT
<b>FRAME</b>	E-COAT

QUANTITY PER CONTAINER					
CONTAINER		SHOP CART QTY. APPROX.	BOX		SHOP CART QTY. APPROX.
SIZE/FT	TYPE		SIZE/FT	TYPE	
20	STANDARD	128	28	STANDARD	240
20	HIGH CUBE	128	40	STANDARD	430
40	STANDARD	280	53	STANDARD	480
40	HIGH CUBE	280			
45	STANDARD	328			
45	HIGH CUBE	328			

COMPETITOR SIZES			
COMPANY	MODEL		
TECHNIBILT			
TOTE			
UNARCO			
UNITED			



COMP. LIST	REQ	NAME & ITEM #	MATERIAL SIZE AND WEIGHT		
		<b>R.W.Rogers Company</b> 610 S. Kirk Rd., St. Charles, IL 60174 Phone: 630-377-9033 * Fax: 630-377-2073 <a href="http://www.rwrogerscompany.com">http://www.rwrogerscompany.com</a>	DRAWN	JL Alvarez	11/02/05
			PROD. READY		
NAME			PART NUMBER		REV
<b>CART INFORMATION</b>			<b>348W</b>		
FINISH		SCALE	SHT	OF	

TOLERANCE UNLESS OTHERWISE SPECIFIED	
FRACTIONS	± 1/32
.00	±.015
.000	±.010
ANGLES	±.15°

DIMENSIONS ARE IN INCHES UNLESS OTHERWISE SPECIFIED	
--	--

REV	REVISIONS	DRAWN	DATE
-----	-----------	-------	------

A  
B  
C  
D  
E  
F  
G  
H  
I  
L  
M  
N  
Q  
R  
S  
V  
W