

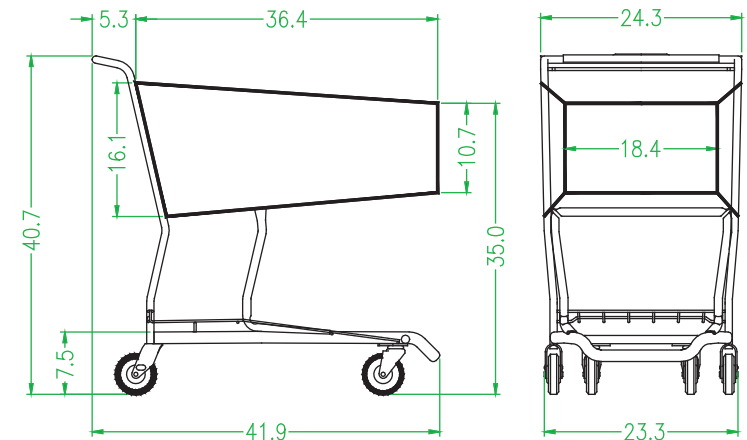

MODEL									
<b>424 W</b>									
<b>TOTAL CAPACITY</b>	17,200	in <sup>3</sup>	<table border="1"> <thead> <tr> <th colspan="2">FINISH</th> </tr> </thead> <tbody> <tr> <td><b>BASKET</b></td> <td>POWDER OVER E-COAT</td> </tr> <tr> <td><b>FRAME</b></td> <td>POWDER OVER E-COAT</td> </tr> </tbody> </table>	FINISH		<b>BASKET</b>	POWDER OVER E-COAT	<b>FRAME</b>	POWDER OVER E-COAT
FINISH									
<b>BASKET</b>	POWDER OVER E-COAT								
<b>FRAME</b>	POWDER OVER E-COAT								
<b>BASKET CAPACITY</b>	9,100	in <sup>3</sup>							
<b>NESTING</b>	12 1/2	in							
<b>WEIGHT</b>	55	lbs							
<b>TRAILER CAPACITY</b>	460	shop. carts							

### FEATURES

Oval tube base - much stronger.  
 Double wire truss basket - stronger, lighter.  
 Drops down gravity assist baby seat - less likely to bind when nesting.  
 7 ga. (0.177) rear caster - stronger, cleaner.  
 Integrated 1" tube, 1/4 X 1 1/2 caster plate - much stronger, cleaner.  
 Welded lower tray - lighter, quieter.  
 Accepts "bumper / caster lifts" - easier to maneuver line of nested carts, less ware on rear wheels.



**R.W. Rogers Company**

610 S. Kirk Rd., St. Charles, IL 60174  
 Phone: 630-377-9033 \* Fax: 630-377-2073  
<http://www.rwrogerscompany.com>

MODEL NUMBER  
**424W**

NAME  
**SHOPPING CART**

DATE  
 04/19/07