

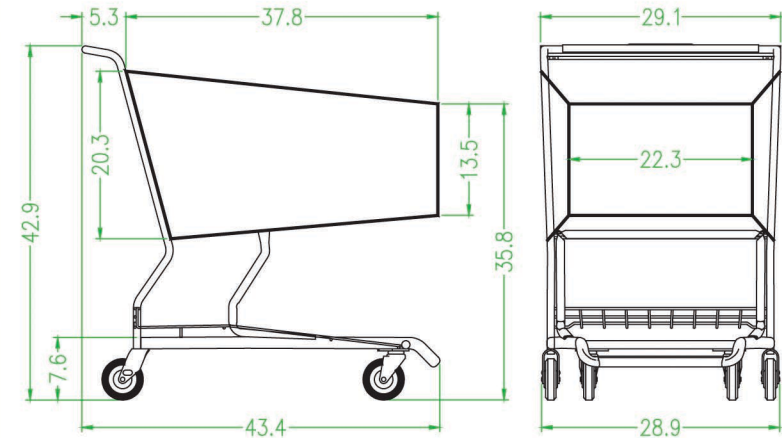

MODEL			568 W		
TOTAL CAPACITY	22,300	in ³	FINISH	BASKET	POWDER OVER E-COAT
BASKET CAPACITY	14,100	in ³			
NESTING	12 1/2	in ³			
WEIGHT	68	lbs		FRAME	POWDER OVER E-COAT
TRAILER CAPACITY	276	shop. carts			

FEATURES

- Oval tube base - much stronger.
- Double wire truss basket - stronger, lighter.
- Drops down gravity assist baby seat - less likely to bind when nesting.
- 7 ga. (0.177) rear caster - stronger, cleaner.
- Integrated 1" tube, 1/4 X 1 1/2 caster plate - much stronger, cleaner.
- Welded lower tray - lighter, quieter.
- Accepts "bumper / caster lifts" - easier to maneuver line of nested carts, less ware on rear wheels.
- Double baby seat.



R.W. Rogers Company
 610 S. Kirk Rd., St. Charles, IL 60174
 Phone: 630-377-9033 * Fax: 630-377-2073
<http://www.rwrogerscompany.com>



MODEL NUMBER
568W

NAME
SHOPPING CART

DATE
 04/18/07